



**KOLBE**



**K 430 / K 430 S**



**K 440**

**BANDSÄGEN BAND SAWS**

# Technische Daten • Technical Data

Bandsägen	Band Saws		K 430	K 430 S	K 440
Raddurchmesser	Wheel diameter	mm	430	430	430
Bandsägeblatt	Bandsaw blade	mm	3370 x 16	3370 x 16	3370 x 16
Bandgeschwindigkeit	Blade speed	m/s	32	32	32
Schnitthöhendurchlass	Pass of cutting height	mm	400	400	400
Schnittseitendurchlass	Pass of cutting side	mm	413	413	413
Schnitthub	Cutting stroke	mm	414	414	411
Portionierbereich	Section of portioning	mm	5 - 280	5 - 280	5 - 280
Tischabmessungen B x T x H	Table dimensions W x D x H	mm	850 x 960 x 910	850 x 960 x 910	850 x 957 x 910
Schiebetisch B x T	Sliding table W x D	mm	-	437 x 442	437 x 522
Maschinenabmessungen B x T x H	Machine dimensions W x D x H	mm	1011 x 1010 x 1970	1011 x 1010 x 1970	1011 x 1012 x 1970
Motorspannung (3Ph)	Motor tension (3Ph)	V	230 / 400	230 / 400	230 / 400
Motorleistung / Schutzart IP54 (Optional)	Motor capacity / Protection system IP54 (optional)	kW	2,9 (4,0)	2,9 (4,0)	2,9 (4,0)
Nennstrom bei 230 V / 400 V	Nominal current at 230 V / 400 V	A	11,8 / 6,8 (14,9 / 8,6)	11,8 / 6,8 (14,9 / 8,6)	11,8 / 6,8 (14,9 / 8,6)
Leiterquerschnitt	Conductor size	mm <sup>2</sup>	2,5	2,5	2,5
Netzabsicherung bei 230 V / 400 V (A träge)	Fusing at 230 V / 400 V (A lazy)	A	16 / 16 ( 20 / 16)	16 / 16 ( 20 / 16)	16 / 16 ( 20 / 16)
Lärmpegel	Noise level	dB(A)	70,5	70,5	70,5
Gewicht netto	Weight net	kg	295 - 305	295 - 305	295 - 305

**K 430 / K 430 S**

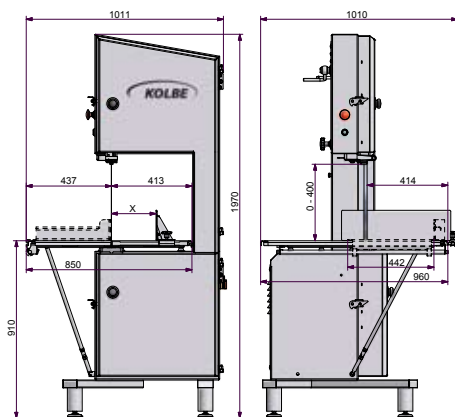

**K 440**

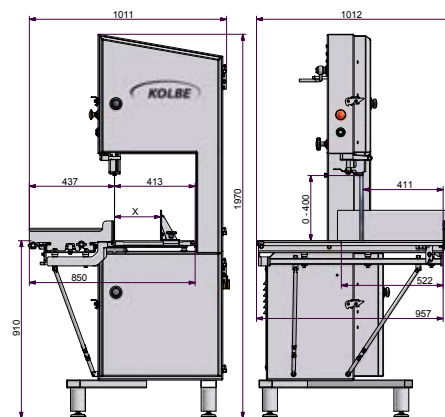

## Ausstattungsmerkmale und Vorteile • Features and benefits



**Schnellspannung**  
Quick tension



**Abstreifer**  
Scrapers



**Kundengerechte Tischvariante**  
Customized solution



**Reinigung**  
Cleaning